

Room Pressure Monitor

Product Description

The Room Pressure Monitor (RPM) is designed for critical low differential pressure applications that require stringent pressure monitoring and alarming. The unit can be configured to monitor positive or negative pressure in protected environments and hospital isolation rooms per CDC guidelines.

Contents

Qty	Description
1	Room Pressure Monitor Assembly
2	Strain relief tubing assembly
3	6-32 × 1/2" mounting screws (for connecting the monitor base to the plaster ring)

Intended Use

The SRPM is designed for indoor use only to monitor critical environments by providing differential pressure indication. Typically, this is between a monitored room and a reference space such as a corridor or ante room. The unit also provides monitoring, alarm and communications functions.

Installation must be indoors, Pollution Degree 2, Installation Category II.

Typical Applications

- Surgical suites
- Intensive care isolation rooms
- Research laboratories
- Pharmaceutical facilities
- Organic laboratories
- Animal research facilities



Expected Installation Time

20 minutes

Product Numbers

Product Number	WC	Protocol	FS
547-101A	+/- 0.05" WC (12.5 Pa)	P1	0.5%
547-102A	+/- 0.1" WC (25 Pa)	P1	0.5%
547-103A	+/- 0.25" WC (62.5 Pa)	P1	0.5%
547-104A	+/- 0.50" WC (12.5 Pa)	P1	0.5%
547-105A	+/- 1.0" WC (250 Pa)	P1	0.5%
547-106A	+/- 2.55" WC (625 Pa)	P1	0.5%
547-107A	+/- 5.0" WC (1250 Pa)	P1	0.5%
547-101B	+/- 0.05" WC (12.5 Pa)	P1	0.25%
547-102B	+/- 0.1" WC (25 Pa)	P1	0.25%
547-103B	+/- 0.25" WC (62.5 Pa)	P1	0.25%
547-104B	+/- 0.50" WC (12.5 Pa)	P1	0.25%
547-105B	+/- 1.0" WC (250 Pa)	P1	0.25%
547-106B	+/- 2.55" WC (625 Pa)	P1	0.25%
547-107B	+/- 5.0" WC (1250 Pa)	P1	0.25%
547-201A	+/- 0.05" WC (12.5 Pa)	BACnet	0.5%
547-202A	+/- 0.1" WC (25 Pa)	BACnet	0.5%
547-203A	+/- 0.25" WC (62.5 Pa)	BACnet	0.5%
547-204A	+/- 0.50" WC (12.5 Pa)	BACnet	0.5%
547-205A	+/- 1.0" WC (250 Pa)	BACnet	0.5%
547-206A	+/- 2.55" WC (625 Pa)	BACnet	0.5%
547-207A	+/- 5.0" WC (1250 Pa)	BACnet	0.5%
547-201B	+/- 0.05" WC (12.5 Pa)	BACnet	0.25%
547-202B	+/- 0.1" WC (25 Pa)	BACnet	0.25%
547-203B	+/- 0.25" WC (62.5 Pa)	BACnet	0.25%
547-204B	+/- 0.50" WC (12.5 Pa)	BACnet	0.25%
547-205B	+/- 1.0" WC (250 Pa)	BACnet	0.25%
547-206B	+/- 2.55" WC (625 Pa)	BACnet	0.25%
547-207B	+/- 5.0" WC (1250 Pa)	BACnet	0.25%

Warning/Caution Notations

WARNING:		Personal injury/loss of life may occur if you do not follow the procedures as specified.
CAUTION:		Equipment damage, or loss of data may occur if you do not follow the procedures as specified.

Required Tools and Components

- Flat-head screwdriver
- (1) Double gang metal electrical box with grounding stud
- (1) 4 × 4-inch metal plaster ring
- (1) Door switch SPDT or SPST, N.O., as needed

For Annunciator and Tap Plate:

- (1) Single gang electrical box

NOTE: Components are not included.

Specifications

Service:	Air or non-conductive, non-explosive gases
Accuracy:	±0.5% F.S., +/-0.25% FS optional
Operating Temperature Limits:	32°F to 120°F (0°C to 50°C)
Operating Humidity Limits:	5 min. to 95% max. RH (non-condensing)
Altitude:	2000 meters (max.)
Thermal Effects:	±0.03% F.S./°F (± 0.05% F.S./°C)
Overpressure:	±15" WC
Supply Voltage:	18-32 Vac, 50-60 Hz
Power Consumption (Voltage Output):	5W
Output:	Selectable 4-20 mA (2-wire) 0-5 Vdc (3-wire), or 0-10 Vdc (3-wire)
Loop Resistance (4-20 mA Output):	0-510 Ω max.
Electrical Connection:	Removable terminal block
Pressure Fittings:	Barbed fittings for 1/4" O.D. tubing
Housing:	Fire retardant plastic (NEMA 1, IP20 rated for indoor applications)
Mounting:	Mounts to customer-supplied 4" × 4" plaster ring (mounts to double gang electrical box)
Dimensions:	8" H × 5.1" W × 1.8" D (203 mm H × 130 mm W × 46 mm D)
Weight approx.:	1.5 lbs (680 grams)
Certifications:	CE, CAN/CSA-C22.2 No. 61010-1-04
Communications:	BACnet MSTP ASC P1 FLN trunk

Installation

The RPM is designed to be mounted on a standard double gang metal electrical box using a 4 × 4-inch plaster ring adapter. Remove the cover and mount the baseplate to the plaster ring adapter using four 6-32, 1/2-inch long mounting screws.

NOTE: The plaster ring external mounting face must be positioned flush to recessed, relative to the surface of the wall. Also note the orientation of the four mounting screws in the plaster ring, as the plaster ring is rotated 90° from conventional mounting.

In the following wiring sections, abbreviations are used, such as, J1, P3.

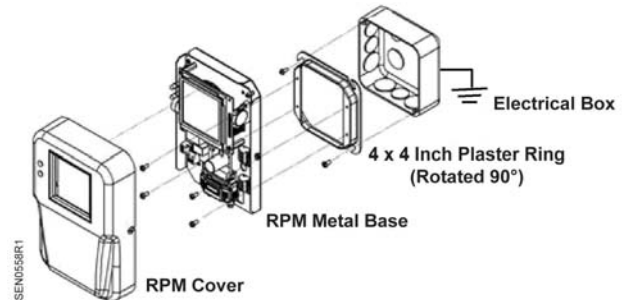

Figure 1. RPM Installation.

Wiring Electrical Box (Rough-In)

1. Lay out the system in terms of wiring: power, annunciator, analog output, BACnet, relay output and plumbing to connect to the monitored spaces (pressure taps).
2. Bring all power, earth ground, signal, communications and analog output wiring into the 4 × 4 electrical box.
3. Bring 1/4-inch O.D. tubing for 3/6-inch barb fitting into box.

In order to conform to the CSA safety standard, the electrical installer must comply with the following earth ground instructions:

- Pre-wire the electrical box with power (24 Vac), and provide earth grounding to the electrical box.
- The safety ground path consists of four 6-32 × 1/2-inch metal screws that connect the RPM metal base to the 4-1/2 × 4-1/2-inch metal plaster ring. The plaster ring must be grounded to the 4-1/2 × 4-1/2-inch electrical box by two metal mounting screws.
- The 4-1/2 × 4-1/2-inch electrical box must be connected to the building earth ground. It is also highly recommended to use armored cable (Type AC) for all the wiring in applications where high levels of radio interference may be present.

- Power leads, analog output, door status, and annunciator wiring should be 14 to 22 AWG stranded wire.
- BACnet suggested wiring is 22 AWG stranded wire in a shielded cable, a +, -, Gnd (S) and shield should be run. This can be two twisted pairs with a separate cable shield. One twisted pair is used for communications, the second twisted pair can be used for communications ground and the shield wire can be connected to the other device shield wires.

Plumbing (Attaching Pressure Tubing)



CAUTION:

Always attach tubing to the RPM header and then place Header onto RPM. This will prevent overpressure from crimped or collapsed tubes.

Use the following procedure for all room types: positive, negative or neutral:

Typically a Pressure Tap Plate is installed in the monitored room. Often, stiff nylon 1/4-inch tubing is used for running pressure signals from the RPM to the monitored spaces. To prevent buckling and collapse of this stiff tubing inside the electrical box, use the supplied strain relief tubing assemblies (2) to transition from the field tubing to the pressure fittings on the RPM. The strain relief tubing assemblies are an integrated system of tubing (2-1/4-inch long), tubing nipple and over-molded spring to prevent crimping or buckling of the tubing in the field.

Attach pressure tubing as follows:

1. Connect the 1/4-inch O. D. tubing running from the Tap Plate (or other pressure connection from the monitored space) to the 4-1/2 × 4-1/2-inch electrical box for the RPM.
2. Install the barbed side of one of the strain relief tubing assemblies onto the end of the field-installed tubing.
3. Thread the tubes through the conduit opening at the bottom of the electrical box.
4. Push the open end of the strain relief tubing assembly onto the RPM pressure tube header (H1) port labeled "+".

NOTE: The header is an Electro-Pneumatic (EP) assembly. "+" indicates (Positive) pressure, and "-" indicates negative or reference pressure.

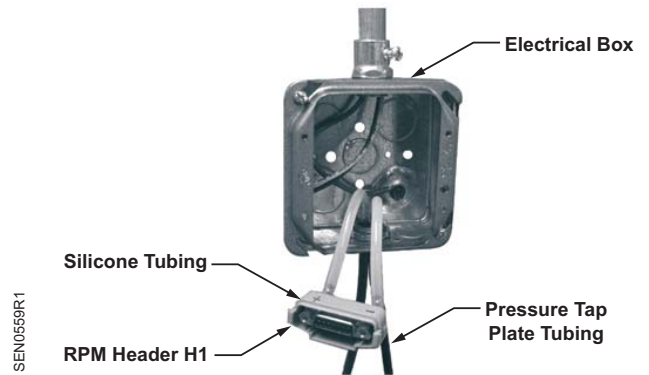

Figure 2. Plumbing Inside Electrical Box.

5. For the most pressure stable operation, a Tap Plate installed in the reference pressure area is also recommended. In this case, install the Tap Plate in a hallway or reference space:
 - a. Attach the tube to the RPM in the same way as for the + port, except attach the tube to the "-" port on the pressure tube header.
 - b. Tighten swivel fittings on the RPM Header H1 assembly if they become loose, 9 in lb. max.
 - c. Verify that the tubes are not buckled, which could close off pressure signal at end of installation.



Figure 3. Pressure Tap Plate.

Wiring, Finish

Alarm Relay Output

The Single Pole Single Throw (SPST) relay output can be used for remote signaling of alarm condition. A form "C" contact rated at 1A is available. Connect to J4, P1 and P4. This relay can be used as a dry contact for remote indication.

Optional Remote Annunciator Wiring

Non-Siemens Remote Annunciator

The RPM can drive annunciators that are powered by a 15V supply, 50 mA max current draw, and accept a 15V trigger. In Figure 4, the Remote Annunciator connector is at left, and the RPM connector is at right:

1. On J4 of the RPM, jumper P1 to P2, this will connect the internal 15V supply to the common of the internal alarm relay.
2. Connect P2 to A1 (Located on Remote Annunciator), this supplies 15V excitation to the Annunciator for powering the circuit during normal conditions.
3. Connect P3 of J4 to A2 of Remote Annunciator J1. This is the 15V power return.
4. Connect P4 of RPM J4 to A3 terminal of Remote Annunciator J1. This is the alarm trigger.

When an alarm occurs and after the programmed alarm delay times out the internal relay will supply 15V to the Annunciator circuit to actuate the audible beeper and the red LED.

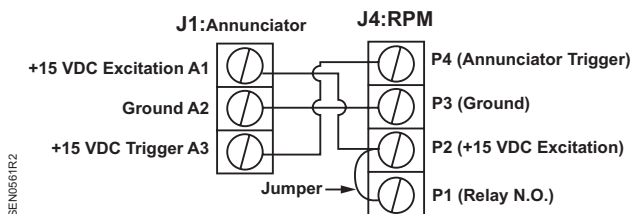

Figure 4. Remote Annunciator Wiring.

Door Status Switch Wiring

1. Install the door switch into the door jamb.
2. Wire to the normally open (N.O.) side of the door jamb contact switch. The RPM will indicate the status of door position. A contact closure indicates that the door is closed. This is a low voltage circuit (5 Vdc).
3. Run two wires from the door switch to connector J6 on the RPM (See Figure 7). The door input status function is enabled in the SETUP ALARMS menu screen.

Analog Output

The RPM can be configured to have either current (4 to 20 mA) or voltage (0 to 5 or 0 to 10 Vdc) outputs. Voltage output—pin 1; Current output—pin 2; Common—pin 3.

NOTE: No external excitation is required.

Current Output

The RPM supplies its own loop power; do not wire in a separate power supply.



Current Output

Figure 5.

Voltage Output

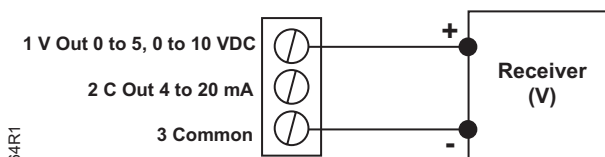

Voltage Output

Figure 6.

BACnet Set-up

BACnet hardware is implemented as isolated RS485. Wire to Connector J2, labeled RS-485. Connect tx line to +(A), rx to -(B) and ground wires to S. Connect Shields together with wire nut.

Hardware configuration is done using a 5-position DIP switch (S1) located in the upper right hand section of the PCBA as well as through the touch screen interface.

Position	Function
1	MAC address enabled
2	N/C Not Connected
3	Pull up resistor
4	Termination resistor
5	Pull down resistor

Use a small, flat-blade screwdriver or pen to push the switch to the right to turn that function on; otherwise, it is off.

There is a BACnet setup screen that is enabled by pushing position 1 switch to the **ON** position. After configuration the switch must be moved to the **OFF** position.

FLN Set-up

FLN hardware is implemented as isolated RS485. Wire to Connector J2, labeled FS-485. Connect tx line to +(A), rx to -(B) and ground wires to S. Connect Shields together with wire nut.

The installation is now complete.

Start-up and Operation

The RPM is designed with as an easy-to-use, intuitive, touch screen interface. In its normal (default) state the Monitoring Screen displays the actual room static pressure, and a slider bar shows the actual pressure relative to the alarm limits. The RGB backlight is used to indicate the condition of the room. The buttons at the bottom of the screen give you access to the functions that can be performed.

Power-Up



Apply power and observe the welcome screen and subsequent transition to the pressure monitor screen. The actual room static pressure is shown as a number in the center of the LCD and visually as a moving bar indicator operating between the preset alarm units. The vertical bar is an indicator of the pressure.

Monitoring Screen

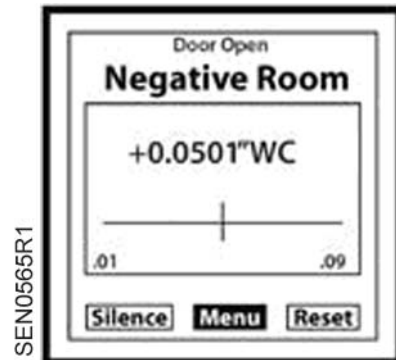

Button	Description
Silence	Shuts off alarm.
Menu	Provides access to Main Menu functions.
Reset	Resets the unit in Latched mode.

The following screens are configuration screens that can be configured so that Password protection is required to make changes. If no entry is made to the screen, the unit will return to the default screen after approximately one minute.

Main Menu Screen

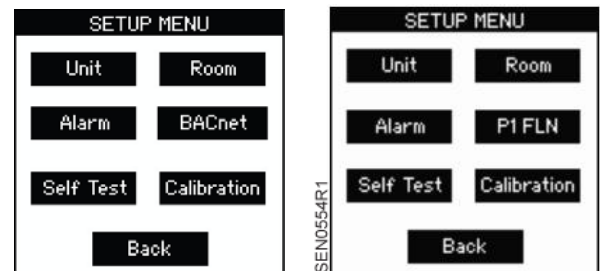

Button	Description
Unit	Sets up supervisor password, output, engineering units, and display averaging.
Room	Sets up high and low pressure limits to monitor a positive, negative, or neutral room. Operator password setup.
Alarm	Sets up latch alarm, audible alarm, door alarm input, mute time out, alarm delay, and volume.
BACnet/P1FLN	Configures BACnet/P1FLN Communications.
Self-test	Identifies product model and software version, and serial number. Verifies memory and performs alarm test.
Calibration	Performs zero and span calibration.
Back	Returns to monitoring screen.

Set-up Unit Operation

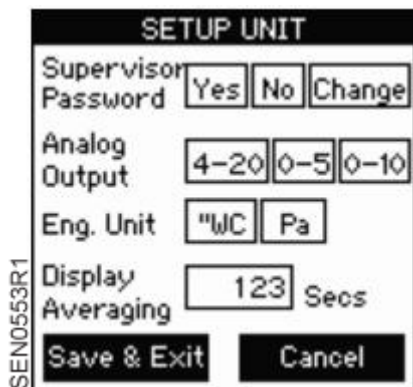

Entering Data

Press (or tap) the button to select an output or engineering unit. Selected button background will change from clear to black.

Password Protection

Lightly pressing (or tapping) the **Yes** button activates Supervisor password protection. With Supervisor password protection enabled, operators cannot access menu screens to update setup. Pressing **No** disables password protection. Pressing **Change** will open **Password Setting Screen**. To change the password, enter the present password (numeric value), followed by the new password in the **New Password** and **Confirm New Password** entry boxes, and then press **Save**. Be careful to store the password for future reference.

NOTE: If the password is lost, **351** can be used to reset the password to a new value.

Analog Output

Select : 4-20, 0-5, or 0-10

Eng. Unit

Select: WC, or Pa

Display Averaging

Lightly pressing (or tapping) the **Display Averaging** box activates the data entry box. Enter from 0 to 60 seconds. Display averaging affects the analog output. Increase the display averaging time to smooth out the pressure readings; this will also reduce the display update rate.

Press **Save** and **Exit**.

Data Entry Screen



Enter numbers by pressing each key in sequence until the desired character is displayed in the data entry box above the keypad.

NOTE: The cursor will blink for one to two seconds and then stop and display the character.

Erase any mistakes by using the **BACKSPACE** (←) key. When data entry is complete, press the **ENTER** key to return to **SETUP UNIT** screen.

NOTE: Use the eraser end of a pencil or back-end of a pen to press (or tap) box on screen to increase accuracy of inputs.

Setup Room Screen

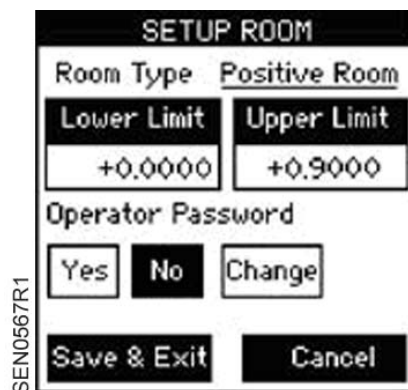

Setup Room Operation

Setup alarm limits for *protective* positive room static pressure, *isolating* negative room static pressure, or *neutral* (where the limits can be – to +).

Entering Data

Lightly press or tap in the **Lower Limit** data entry box. Enter the lower limit pressure. Lightly press or tap in the **Upper Limit** data entry box. Enter the upper limit pressure. The **Room Type** box will change depending on the lower and upper limits. If both entries are positive, the room will be a Positive Room. If both are negative, the room will be a Negative Room. If the lower limit is negative and the upper limit is positive, the room will be a Neutral Room.

Operator Password

The operator can only enable or disable the room alarms.

Lightly pressing (or tapping) **Yes** activates Operator Password Protection. With Operator Password Protection enabled, room Enabled/Disabled status cannot be changed without entering a valid operator password. Pressing **No** disables password protection. Pressing **Change** will open the **Password Setting Screen**. To change the password, enter the present password, followed by the new password in the **New Password** and **Confirm New Password** entry boxes, and then press **Save**. Be careful to save the operator password for future reference.

NOTE: If the password is lost, **351** can be used to reset the password to a new value.

Setup Alarms Screen



From this screen you can access the following:

- **Latch Alarm** - Requires the pressure to return to normal and the alarm to be acknowledged before the alarm can be silenced and reset.
- **Audible Alarm** - Enable by selecting **Yes**, or use visual only alarm by selecting **No**.

- **Door Alarm Input** - Provide a “door open” warning visual indication. When a door jamb contact switch is used and this button is activated by pressing **Yes**, the door status “open” condition is indicated by the touch screen display turning from green to yellow, and door open indicated on the monitoring (default) screen.
- **Mute Time Out** - Set the time (in seconds) that the alarm can be silenced in the Latched Alarm mode before the alarm resumes. This assumes that the room static pressure is still outside the normal or set operating limits. The Mute Time Out can be set from 0 to 9999 seconds.
- **Alarm Delay** - Set the Alarm Delay (in seconds) from the time that the room pressure goes out of the preset limits until the alarm activates. The alarm delay may be set from 0 to 9999 seconds.
- **Volume** - Set the alarm volume or sound level. Using the **Up** and **Down** keys, the volume can be set at level 1 to 4. Level 4 alarm volume is the loudest and corresponds to a sound level of 85 dB at a distance of 4 inches.

Alarm Setup Operation

Lightly press (or tap) the button to select **Yes** or **No** for Latch Alarm, Audible Alarm, or Door Alarm Inputs. Selected box background will change from clear to black when selected.

Mute Time Out/Alarm Delay

Pressing (or tapping) the **Mute Time Out** or **Alarm Delay** box activates the Data Entry screen to set the time delay duration.

Self Test Screen



This screen identifies the Product Model Part Number and Software Version.

You can also perform a self-test of the unit to verify that the data in the protected area of the EEPROM memory hasn't been corrupted, and test the alarm to verify the sound level and alarm setup.

Press the **Self Test** button to initiate an EEPROM memory checksum test sequence.

Press **Alarm Test** to test beeper, visual Red LED Alarm, and relay output. This can be used to verify the system in Alarm Mode.

Press **Cancel Test** to stop the alarm test.

Press **Exit** to return to the Main Menu.

BACnet Setup Screen



1. Enable the **MAC address** enable switch (S1) on the DIP switch by pushing it to the right.
2. Set **Device Address** – Enter the address of the device
3. **Select Baud Rate** – Press the correct baud rate button (9600 to 76800).
4. Press **Save & Exit** to save settings, or **Cancel** to cancel the setting changes.
5. When complete, disable the BACnet setup by moving the DIP switch position 1 to **Off** (left) position.
6. If the unit will be at the end of the line, the pull up resistor can be enabled by pushing position 3 to **On**.
7. The termination resistor can be inserted by pushing position 4 switch to **On**.
8. The pull down resistor can be enabled by turning position 5 to **On**.
9. Press **Save & Exit**. After the unit returns to the Main Menu screen, disconnect the power to the unit, then reconnect to boot-up with the proper **MAC Address** and **Device Instance**.

DIP Switch Position	Function
1	MAC address enabled
2	Not Used
3	Pull Up Resistor
4	Termination Resistor
5	Pull Down Resistor

Contact Siemens Industry, Inc. for information on Point list and PICS and BIBBS statements.

FLN Setup Screen

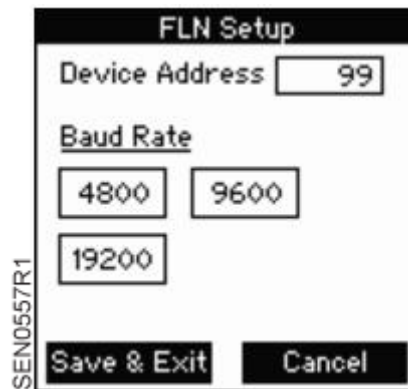

To set up FLN communications:

1. Set **Device Address** – Enter the address of the device.
2. Select **Baud Rate** – Press the correct baud rate button (4800 to 19200).
3. Press **Save & Exit** to save settings, or **Cancel** to cancel the setting changes.

Pressure Monitoring Screens

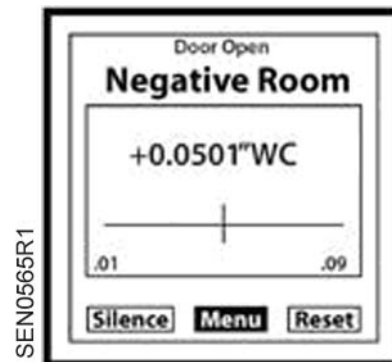

Changing Room Alarm Modes



The Room Pressure Monitor can be quickly changed from Enabled monitor and alarming to Disabled (or unoccupied). To do this, touch the room mode indicator at the top of the pressure monitoring screen.

Enabled/Disabled

Use these buttons to quickly change the room to **ENABLED** or **DISABLED** status. If **DISABLED** is used there will be no alarms generated if the room is outside pressure limits.

Press **Save & Exit**.

Calibration Screen



The device is designed to operate without routine calibration. However, it should be periodically re-zeroed as follows:

1. Open the device cover.
2. Disconnect the electro-pneumatic Header H1 so that room pressures are not applied to the pressure sensor.
3. On the Calibration screen, lightly press (or tap) the **ZERO** button.

4. Reconnect the electro-pneumatic Header H1 and close the cover.

If a sufficiently accurate pressure calibrator is available, then span calibration can also be performed. The calibration unit needs to be more accurate than the RPM, depending on the facility's calibration requirements. The **WC** and **FS** columns in the *Product Numbers* table on the first page of this document the water column and full scale accuracy of each RPM.

To calibrate the span:

1. Open the device cover.
2. Apply a steady full-scale pressure signal to the **+** on the header fitting and press (or tap) the **SPAN** button.
3. Reconnect the room pressure tube and calibration is complete. Calibration must be within $\pm 5\%$ of original calibration for this to occur; otherwise, an error message will occur.

To restore the original factory pressure calibration, press the **Restore Factory Calib** button.

Maintenance

The Room Pressure Monitor is designed to operate in an indoor environment, and monitor clean, dry air.

Upon final installation of the Room Pressure Monitor, no routine maintenance is required. A periodic check of system calibration is recommended, as described in the *Calibration Screen* section. The unit is not field serviceable and should be returned if repair is needed (field repair should not be attempted and may void warranty). Be sure to include a brief description of the problem plus any relevant application notes. Contact Customer Service to receive a return goods authorization number before shipping.

Cleaning



CAUTION:

Do not blow into the pressure tubing or fittings with mouth, compressed air, or canned air. Such actions may permanently damage the pressure sensor.

Do not clean or wash-down the unit with industrial cleaners or solvents. The housing may be wiped down with soap and water or isopropyl alcohol. The LCD may only be cleaned with isopropyl alcohol. Do not immerse unit.

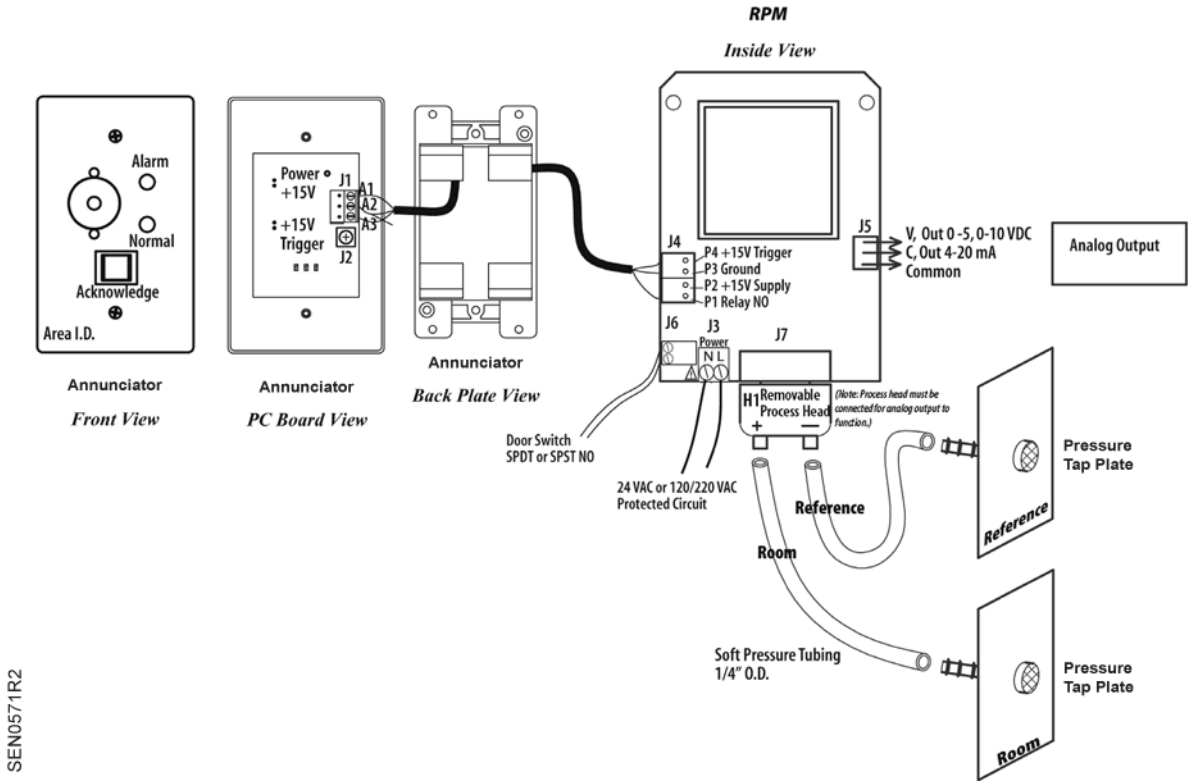

Figure 7.

SEN0571R2

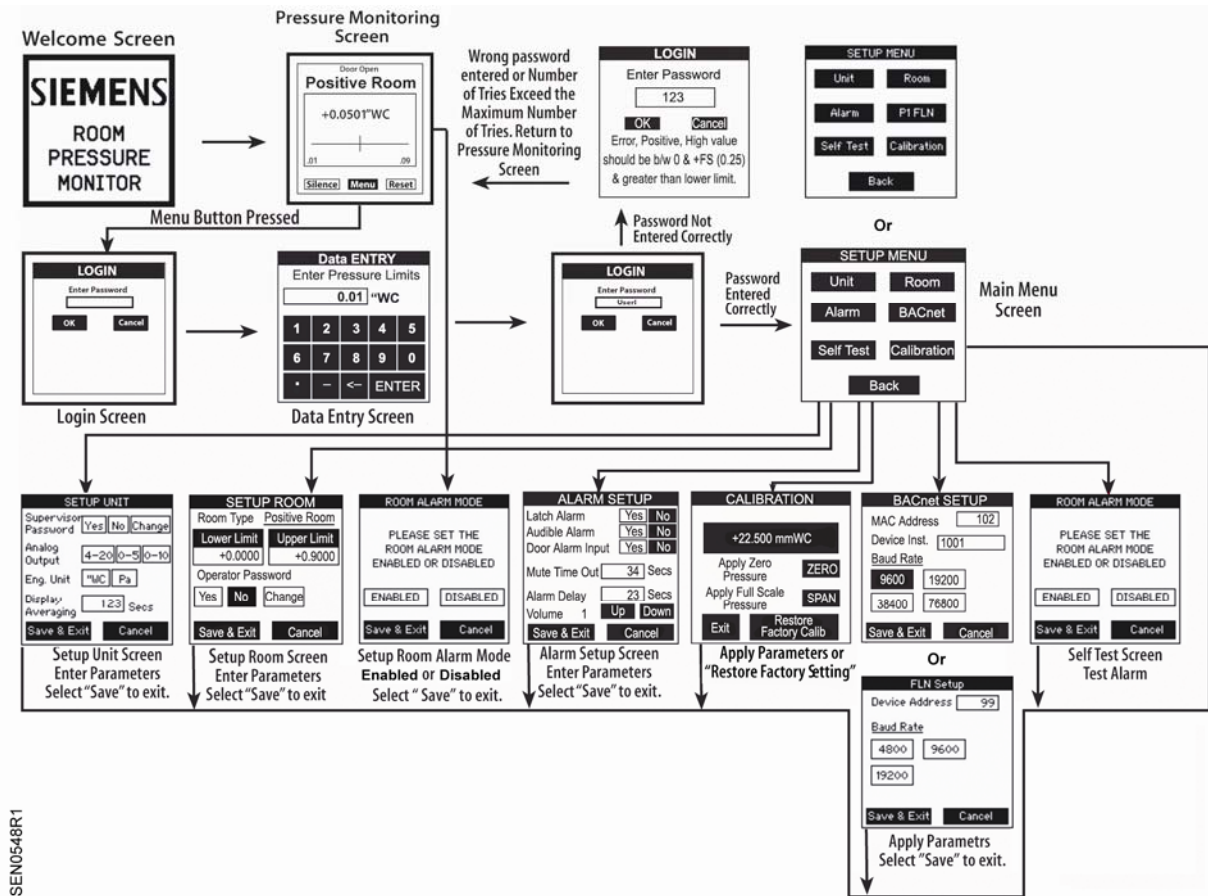

Figure 8. Menu Tree.

Information in this publication is based on current specifications. The company reserves the right to make changes in specifications and models as design improvements are introduced. Product or company names mentioned herein may be the trademarks of their respective owners. © 2013 Siemens Industry, Inc.